



THE ASCOT
FREESTANDING GAS STOVE





THE ASCOT

FREESTANDING GAS STOVE

Gas Stove Details

Maximum BTU Input	17,000 BTU
Minimum BTU Input	9,000 BTU
Area Heated**	1000 ft ²
Steady State Efficiency	82%
EnerGuide FE Rating (LP)	66%
Finish Options	Painted Black – Matte Antique Chestnut – Enamel

** Efficiency and area heated will vary according to gas type and venting.
Approved for sale in Canada and the United States.

Clearance to Combustibles

Min. distance to the sides of the unit	10"
Min. non-combustible surface behind the unit	2.5"
Min. non-combustible surface from above the unit	42"

Please see owner's manual for more information

Ascot Features

- Field conversion kit NG to LP
- Thermostat or remote compatible
- Ceramic log set
- 5mm ceramic glass
- Heavy duty heat exchanger
- Metallic black paint
- Easy access control panel
- Battery powered ignition system
- Cast iron body and legs
- Direct vent system
- Quick release glass door system
- Unique "Enviro EmberGlo" pan-style stainless steel burner

Available Options

- 150 CFM variable speed fan
- Clip-on fire screen
- Choose from 4 different
- Antique chestnut porcelain finish
- B-Vent adaptor



The Ascot uses a heavy-duty heat exchanger and quick release glass door system for easy cleaning.

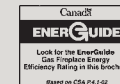
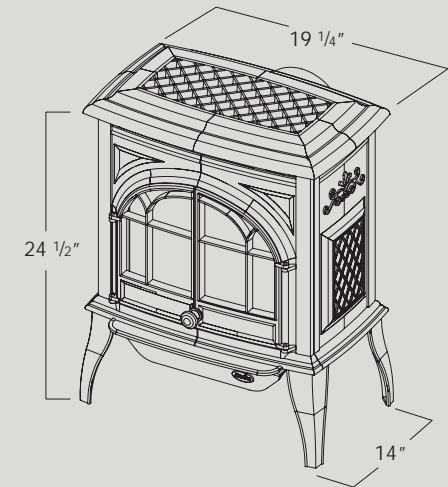
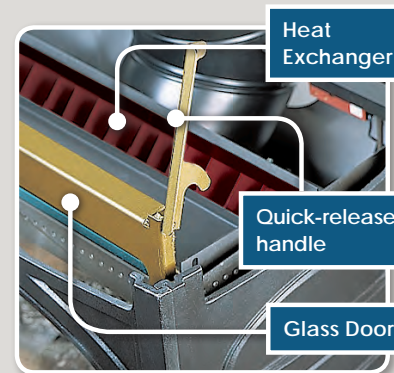

Please share and recycle this brochure

Manufactured by Sherwood Industries Ltd ▪ Victoria, BC, Canada
enviro.com ▪ info@enviro.com ▪ Printed in Canada, April, 2013